

## Fume Hood General Specifications:

### A. STRUCTURAL EXTERNAL:

All external components and materials are fabricated from furniture grade cold rolled steel a minimum of 18 gauge. The steel is then treated in a passivating/etching bath and washed clean of oils and rust. After the cleaning process the metal is then rinsed off and placed in an oven for drying. After drying is complete the pre-selected chemical resistant finish is applied using modern powder coating processes. After the powder has been applied the parts are then returned to the bake oven for a heat cycle and then left to cool before removal to be assembled.

All fume hoods use a double wall construction feature utilizing a rigid frame construction. The outer and inner components are fastened together to complete the construction. Sash construction is also a minimum of 16 gauge steel either carbon or stainless steel all one piece laser cut and formed for added strength and rigidity. The sash is formed to provide a continuous finger lift across the complete sash assembly. All glass is removable via retainers located on the back side of the sash. All safety glass is ¼" thick dual paned laminated trimmed in a "U" shaped neoprene rubber channel sealed. Note for sash 70" and larger we typically add a center mullion to improve strength. The sash is attached to a counter balance weight located in the back of the hood via a 3/16" thick nylon coated aircraft cable. The cable ride on nylon clevis with a steel ball bearing hub for years of dependable quiet use.

### B. STRUCTURAL INTERNAL

The interior lining is manufactured from a white poly resin board from 3/16" to ¼" thick. The liner is manufactured to eliminate screw heads and reduce air flow obstructions. The standard fume hoods also offer gasket sealed access panels on both sides. This allows access into the plumbing and electrical service areas. No special tools or requirements for removing and reinstalling the access panels. Standard wall spacing from the outside to the inside is 5". All interior components are replaceable or removable for cleaning. The baffle system is set with a middle inlet at approximately 18" off the work surface along with upper and lower inlets to improve exhaust patterns. The working height for most models will be a minimum of 48" unless noted.

The material is easily cleaned and resists the growth of bacteria and microbial penetration. The material is also flame resistant and non-heat sensitive. This product is also a U.L. approved product. Special application liners are also offered for more details see accessories section.

### C. PRE-WIRE

Some fume hoods require all electrical components be pre-wired prior to delivery. Only certified electricians are allowed to install and wire the electrical components based on applicable national codes. Typically all wiring is routed to a junction box located on top of the fume hood. This includes all light switches, blower switches, simplexes, receptacles, and alarm systems. Only steel conduit is allowed to be used. All wire sizes are based on load requirements. Lighting is designed to provide the maximum amount of light source generated by the respective attached fixture. As per specifications we meet or exceed the 80 foot-candles in the working area. All fixtures are UL rated and approved for there specific application. All final connections made by respective trades.

### D. PRE-PLUMB

Some fume hoods require the instillation of plumbing fixtures. All fixtures are installed per national plumbing codes. Piped according to national codes. The customer will designate if the piping will be down, up, or to the back. All piping will terminate within the confines of the fume hood typically 2-3" prior to the outer skin. All final connections made by respective trades.

### E. AIRFOIL

Where applicable the airfoil is a directional flow vane mounted to the front of the fume hood at the work surface. It is used to direct air across the work surface even when the sash is closed. It is usually used with By-pass hoods specifically. The airfoil is manufactured from both 304 stainless steel or carbon steel both a minimum of 16 gauge material. The airfoil is powder coated for a chemical resistant finish or if it is stainless steel buffed and polished unless also powder coated per specifications. The airfoil is mounted after the hood is installed per specific trades.

### F. ALARMS & LOCKS

All alarms are mounted per manufactures specifications to obtain the best possible readings. This also may include the use of a stop or lock mechanism to maintain optimum operating levels. Sensors are also applied for this application as well with audio and visual alarms to warn users of misuse. All alarms meet ANSI, OSHA, and ASHRAE criteria for safe operation within the laboratory environment. For specific codes and compliance refer to sales representative or the factory.

### G. TESTING & APPROVAL

All fume hoods meet ASHRAE 110-1995 testing requirements set forth by ASHRAE. This includes the complete line of Keur Industries fume hoods. For specific test results please contact your sales representative or the factory. All fume hoods meet the Federal governments OSHA standards for safe operation within the laboratory environment. All fume hoods are constructed to meet U.L. 1805 classification and manufactured from approved materials only.

### H. FUME HOODS

All specifications apply to the various types of fume hoods manufactured by Keur Industries. For the complete list see this catalog or visit our website at [www.keurind.com](http://www.keurind.com).

### I. INSTALLATION

The internal frame structure has pre-punched holes for deck mounting either through the interior access panels or by removing the external side panels. The fume hood is typically mounted to an epoxy resin work surface using stainless steel machine screws or is bolted to the top. All mounting hardware should be stainless steel to increase the life of the install. For seismic conditions a secondary upper and lower bracket system is used to secure the hoods frame to walls or ceiling structures.

# FUME HOODS

## Rough In Dimensions and Specifications for HVAC and Plumbing connections:

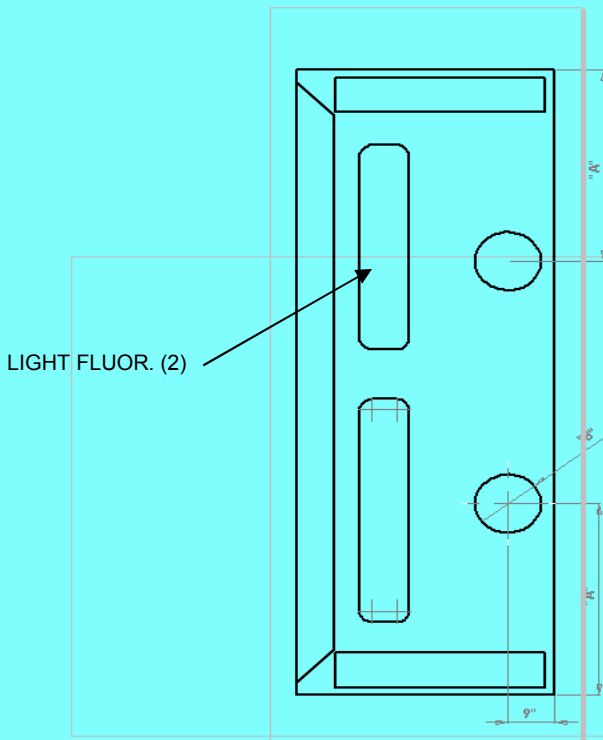

### SIZING CHART FOR DIMENSIONS OF EXHAUST DUCTS

- 84" FUME HOOD DIMENSION "A" = 23 1/2" "B" = 9" DIA.
- 94" FUME HOOD DIMENSION "A" = 24" "B" = 10" DIA.
- 96" FUME HOOD DIMENSION "A" = 25" "B" = 10" DIA.

MODELS 84" WIDE AND LARGER

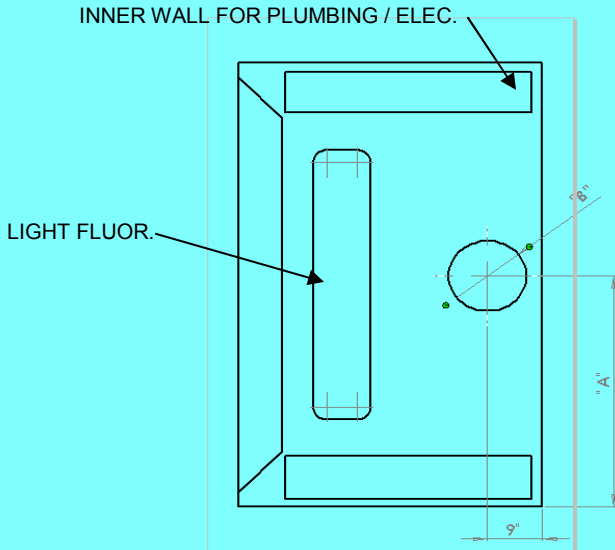

### SIZING CHART FOR DIMENSIONS OF EXHAUST DUCTS

- 35" FUME HOOD DIMENSION "A" = 17 1/2" "B" = 8" DIA.
- 36" FUME HOOD DIMENSION "A" = 18" "B" = 8" DIA.
- 47" FUME HOOD DIMENSION "A" = 23 1/2" "B" = 9" DIA.
- 48" FUME HOOD DIMENSION "A" = 24" "B" = 9" DIA.
- 58" FUME HOOD DIMENSION "A" = 29" "B" = 10" DIA.
- 60" FUME HOOD DIMENSION "A" = 30" "B" = 10" DIA.
- 70" FUME HOOD DIMENSION "A" = 35" "B" = 10" DIA.
- 72" FUME HOOD DIMENSION "A" = 36" "B" = 10" DIA.

MODELS 35" TO 72" WIDE

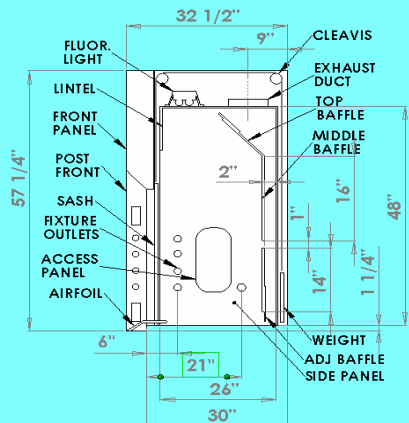

Side Profile for plumbing rough in