

## FUME REMOVAL SYSTEMS:

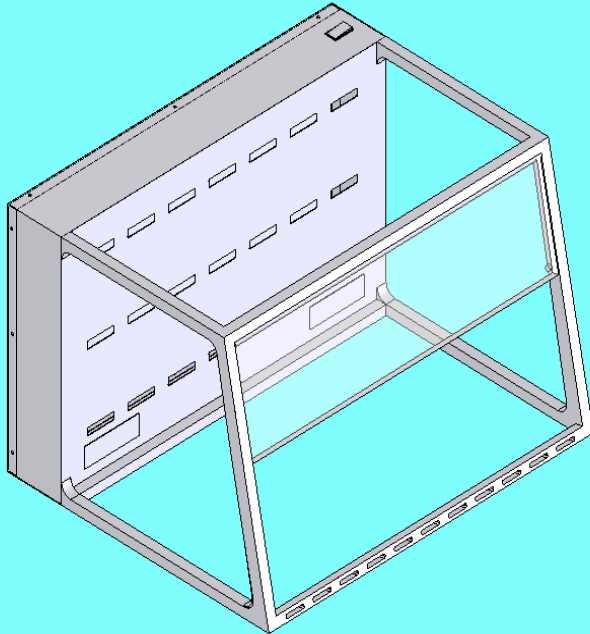

### VENTILATION STATION EXTRACTOR SYSTEM –

This system works well in class rooms for clear viewing from all three sides. It has a built in filtration system completely removable and has its own blower. The air is discharged out the back of the system. It can discharge into the room or it can also be ducted out to discharge into the environment. Duct sold separately. The body is manufactured from CRS typically 18 gauge and is powder coated white. The view windows are all sealed in frames. The windows themselves are ¼” thick clear acrylic including the swing open front panel. This allows for easy material loading and unloading as needed. Electrical outlets can be provided on the inside as needed. This model comes with filter, blower, and 8’ power cord.

#### Standard Features:

- 6” diameter exhaust duct with 1” collar
- Integrated airfoil front frame
- Outlet locations punched as needed
- Easy access into blower compartment
- 8’ power cord
- Toggle type blower switch
- Flip up front sash for easy loading
- Optional cart mounting
- Built in blower
- Carbon charged filter

Above: MODEL NUMBER **100-036-VTS**

Each model comes with 8’ cord standard plug configuration all Models use 115V. outlet for power source.

Model # **100-036-VTS** this complete system is 29” deep, 24” high, and 36” wide

Model # **100-024-VTS** this complete system is 29” deep, 24” high, and 24” wide

Below: MODEL NUMBER **100-FAC-028**

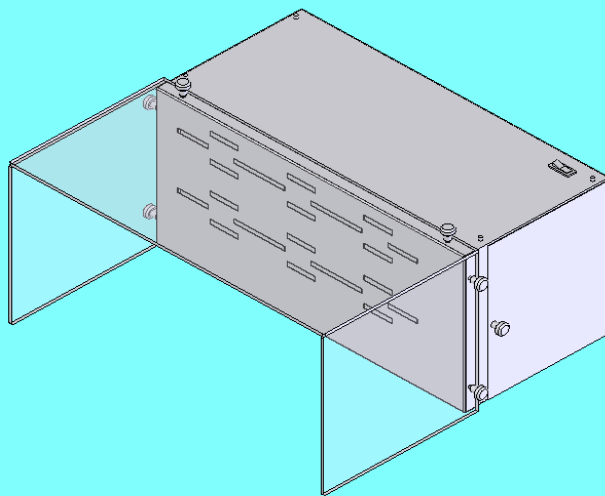

### FUME ABSORBER SYSTEM –

This system is manufactured to provide odor relief during manufacturing processes. Typical applications include xylene and toluene exposure. With the absorbers carbon charged filter system and built in blower it is a clean safe way to protect your employees from over exposure. Filters are easily changed by accessing the filter compartment in the back. The clear acrylic view windows can be removed or configured as needed to provide the best possible working environment. The body of the absorber is manufactured from 18 gauge white powder coated furniture steel. The power on off switch is a lighted toggle type located at the top of the unit. This system discharges the air back into the same space after the odor purging process.

#### Standard Features:

- Filter carbon charged type
- 8’ power cord
- Removable shield
- Toggle on / off switch illuminated
- Built in blower

Model # **100-028-FAC** this complete system is 26” deep, 13” high, and 28 ½” wide

Model # **100-012-FAC** this complete system is 26” deep, 13” high, and 12 ½” wide